



Internal Combustion Engine Counterbalance Truck

H20 – H35

Capacity 2.0 – 3.5 t | Series 1202

Robust Performer with All-Round Visibility

- Hydrostatic drive, dual pedal control and Linde Load Control enable efficient load handling
- Robust construction and maintenance-free components guarantee high truck availability
- Slim mast profiles, narrow A-pillar, lowered front plate and see-through roof ensure outstanding visibility
- Wireless data transmission aids effortless integration into software systems, e.g. for fleet management.
- The truck's low center of gravity and intelligent assistance systems reduce the risk of tipping and loading accidents



Here you can find more content via your smartphone: [Linde Augmented Reality App](#)



LOAD CAPACITY

H20 / 600

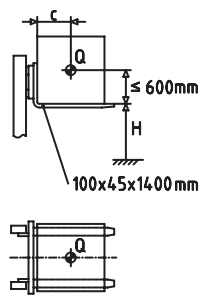

H (mm)	Q (kg)			
6800	1300	1180	1090	1000
6700	1380	1250	1150	1060
6600	1460	1330	1220	1120
6500	1530	1400	1250	1180
6400	1610	1470	1350	1240
6300	1690	1540	1410	1300
6200	1770	1610	1480	1360
6100	1840	1680	1540	1420
6000	1920	1750	1610	1480
≤ 5900	2000	1820	1670	1540
c (mm)	400 - 600	700	800	900

H25

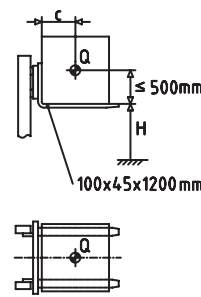

H (mm)	Q (kg)			
6800	1500	1350	1230	1130
6600	1650	1490	1360	1250
6400	1810	1630	1480	1360
6200	1880	1700	1550	1420
6000	1960	1770	1610	1480
6100	2040	1840	1670	1540
6000	2120	1910	1740	1590
5900	2190	1980	1800	1650
5800	2270	2050	1860	1710
5700	2350	2120	1930	1770
5600	2420	2180	1990	1830
≤ 5500	2500	2250	2050	1880
c (mm)	400 - 500	600	700	800

H25 / 600

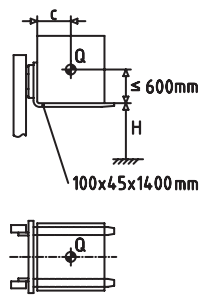

H (mm)	Q (kg)			
7000	1700	1550	1420	1320
6900	1800	1640	1510	1400
6800	1900	1730	1590	1470
6700	2000	1820	1680	1550
6600	2100	1910	1760	1630
6500	2200	2000	1840	1710
6400	2300	2100	1930	1790
6300	2400	2190	2010	1860
≤ 6200	2500	2280	2100	1860
c (mm)	400 - 600	700	800	900

H30

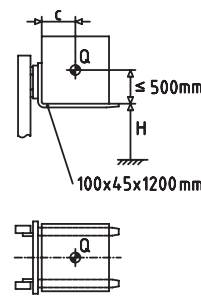

H (mm)	Q (kg)			
7000	2000	1810	1650	1520
6900	2100	1900	1730	1600
6800	2200	1990	1820	1670
6700	2300	2080	1900	1750
6600	2400	2170	1980	1820
6500	2500	2260	2060	1900
6400	2600	2350	2150	1980
6300	2700	2440	2230	2050
6200	2800	2530	2310	2130
6100	2900	2620	2400	2190
≤ 6000	3000	2710	2480	2190
c (mm)	400 - 500	600	700	800

H35

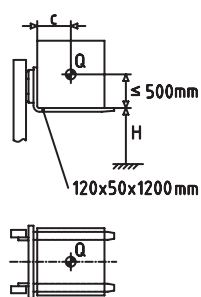

H (mm)	Q (kg)			
7000	2000	1810	1650	1520
6800	2220	2010	1840	1690
6600	2440	2210	2020	1860
6500	2550	2310	2110	1940
6400	2660	2410	2200	2020
6300	2770	2510	2290	2110
6200	2880	2610	2380	2190
6100	2990	2700	2470	2270
6000	3100	2810	2560	2360
5900	3230	2930	2670	2460
5800	3370	3050	2780	2560
≤ 5700	3500	3170	2890	2660
c (mm)	400 - 500	600	700	800

H = Lifting height, c = Load centre, Q = Load capacity

Load capacity for standard mast and fork carriage

STANDARD AND OPTIONAL EQUIPMENT

H20-H35 CNG		H20 - H35 D	H20 - H35 T	H20-H35 CNG
Operator Compartment	Ergonomic and save truck access due to a low entry step and handle bar at a-pillar and bonnet	●	●	●
	Innovative decoupling concept for lowest human vibrations	●	●	●
	Tilt adjustable steering column	●	●	●
	Overhead guard comfort for max. head clearance	●	●	●
	Operator's seat - mechanical quick weight adjustment	●	●	●
	Various seating options such as heating, air suspension, active seat ventilation, longitudinal suspension	○	○	○
	Operators seat - Swiveling seat	○	○	○
	Coloured 3.5" LED display with steering angle indicator and tilt angle indicator	●	●	●
	Coloured 7" LED multifunction display integrates additional functions e.g. cameras and Linde Safety Pilot	○	○	○
	Top screen armored glass	○	○	○
Driving and Lifting	Alloy doors with openable window	○	○	○
	Din A4 illuminated clipboard	○	○	○
	Warm water heater incl. defog function/air conditioning	○	○	○
	Radio, DAB+, MP3 Player incl. bluetooth hands-free equipment	○	○	○
	Linde Hydrostatic Drive - for high productivity and low fuel consumption	●	●	●
	Deutz Diesel Engine EU 2016/1628 Stage 5*	●	-	-
	Deutz CNG Engine EU 2016/1628 Stage 5*	-	-	●
	Particel filter, oxidation catalysts, exhaust gas recirculation	●	-	-
	Deutz LPG Engine EU 2016/1628 Stage 5*	-	●	-
	3-Way Catalyst	-	●	●
	LPG tank including fill level indicator in the display	-	○	-
	Engine air filter including safety elements	●	●	●
	Linde Engine Protection System (LEPS) - warning, speed reduction under critical engine conditions	●	●	●
	Hydraulic parking brake	●	●	●
	Oversized, variable displacement pump for lifting function - for low fuel consumption, low noise level and emissions	●	●	●
	Hydraulic filter concept - realizing 6000 hour hydraulic-oil change interval	●	●	●
	Power setting efficiency, economy, performance	●	●	●
	Super Elastic (SE) Tyres	●	●	●
	Closed Shoulder Tyres CS 20	○	○	○
	Pneumatic Tyres	○	○	○
Antistatic, non marking Tyres	○	○	○	
Anti-spray mudflaps front and rear	○	○	○	
Mast	Top mounted tilting cylinders - including maintenance free bearings	●	●	●
	Best visibility through asymmetric, nested mast profiles on standard, duplex, triplex masts	●	●	●
	Electronic damped tilt stop	●	●	●
Attachments/ Forks	Hydraulic accumulator for high driving comfort and less wear	○	○	○
	Reinforced Linde forks - easy ajustable and long life time	○	○	○
	Integrated sideshift with full lift capacity and roller guided	○	○	○
	Integrated fork positioner "View" for high residual capacities and optimized visibility	○	○	○
Safety	Street sweeper preparation	○	○	○
	Linde Curve Assist - automatic drive speed reduction when cornering	●	●	●
	Electrical seat belt monitoring - visual and acoustic feedback	●	●	●
	Linde Load Assist - increased safety at high lift heights	●	●	●
	BlueSpot and TruckSpot - optical warning signal for pedestrians and drivers	○	○	○
	Load weight indicator	○	○	○
	Linde Safety Pilot - load-dependent travel and lifting speed intervention plus additional functions	○	○	○
	Linde Safety Guard - truck to truck warning and truck to pedestrian warning	○	○	○
Digitalisation	Speed limitations (via switch, indoor-outdoor, load depending)	○	○	○
	Restraint systems (different options)	○	○	○
	Data Transmission Online	●	●	●
	Data Transmission Wifi	○	○	○
	Linde connect:desk - local fleet management with different functional modules	○	○	○
Operation/ Load Handling	Linde connect:cloud - fleet management as a service (hosted version)	○	○	○
	Pre-Operation-Check - individualizable daily check protocol for operational readiness	○	○	○
	Truck Call App - coordination of transport orders	○	○	○
Operation/ Load Handling	Double pedal control - Stepless acceleration and fast reversing	●	●	●
	Single pedal control - Stepless acceleration	○	○	○
	Linde Load Control - central levers fully integrated in the armrest for precise control of all hydraulic functions	●	●	●
Individual Lever System	○	○	○	

● Standard equipment ○ Optional equipment - Not available

TECHNICAL DATA (According to VDI 2198)

Characteristics	1.1	Manufacturer	Linde	Linde	Linde	Linde	Linde	Linde	Linde	Linde	Linde	Linde	LINDE	LINDE	LINDE	
	1.2	Model	H20 / 600 D	H25 D	H25 / 600 D	H30 D	H35 D	H20 / 600 T	H25 T	H25 / 600 T	H30 T	H35 T	H35 D Container	H35 D Beverage	H35 CNG	
Weights	1.3	Power unit	Diesel	Diesel	Diesel	Diesel	Diesel	LPG	LPG	LPG	LPG	LPG	Diesel	Diesel	CNG	
	1.4	Operation	Seat	Seat	Seat	Seat	Seat	Seat	Seat	Seat	Seat	Seat	Seat	Seat	Seat	
	1.5	Load capacity/Load	Q (t)	2	2.5	2.5	3	3.5	2	2.5	2.5	3	3.5	3.5	3.5	
Wheels/Tyres	1.6	Load centre distance	c (mm)	600	500	600	500	500	600	500	600	500	500	500	500	
	1.8	Axle centre to fork face	x (mm)	416.50	416.50	455.50	448.50	453.50	416.50	416.50	455.50	448.50	453.50	453.5	453.5	
	1.9	Wheelbase	y (mm)	1865	1905	1905	1930	1965	1865	1905	1905	1930	1965	1965	1965	
	2.1	Service weight	(kg)	3738	3918	4480	4635	4978	3712	3891	4453	4609	4952	4950	5302	5016
	2.2	Axle load with load, front/rear	(kg)	4916/822	5560/858	6001/979	6657/978	7487/991	4885/827	5528/863	5970/983	6626/983	7456/996	7458/992	7667/1135	7460/1056
	2.3	Axle load without load, front/rear	(kg)	1826/1912	1857/2061	2116/2364	2183/2452	2289/2689	1795/1917	1825/2066	2085/2368	2152/2457	2258/2694	2260/2690	2469/2833	2262/2754
	3.1	Tyres rubber, SE, pneumatic, polyurethane		SE	SE	SE	SE	SE	SE	SE	SE	SE	SE	SE	SE	
Dimensions	3.2	Tyre size, front		225/75 - 10 (23 x 9 - 10)	225/75 - 10 (23 x 9 - 10)	250/75 - 12	250/75 - 12	250/75 - 12	225/75 - 10 (23 x 9 - 10)	225/75 - 10 (23 x 9 - 10)	250/75 - 12	250/75 - 12	250/75 - 12	250/75 - 12 (27 x 10 - 12)	250/75 - 12 (27 x 10 - 12)	250/75 - 12 (27 x 10 - 12)
	3.3	Tyre size, rear		6.50 - 10	6.50 - 10	225/75 - 10 (23 x 9 - 10)	225/75 - 10 (23 x 9 - 10)	225/75 - 10 (23 x 9 - 10)	6.50 - 10	6.50 - 10	225/75 - 10 (23 x 9 - 10)	225/75 - 10 (23 x 9 - 10)	225/75 - 10 (23 x 9 - 10)	225/75 - 10 (23 x 9 - 10)	225/75 - 10 (23 x 9 - 10)	225/75 - 10 (23 x 9 - 10)
	3.5	Wheels, number front/rear (x = driven)		2x/2	2x/2	2x/2	2x/2	2x/2	2x/2	2x/2	2x/2	2x/2	2x/2	2x/2	2x/2	2x/2
	3.6	Track width, front	b10 (mm)	972	972	1008	1008	1008	972	972	1008	1008	1008	1008	1008	1008
	3.7	Track width, rear	b11 (mm)	961	961	961	961	961	961	961	961	961	961	961	961	961
	4.1	Mast/fork carriage tilt, forward/backward	a/b (°)	5.0/8.0	5.0/8.0	5.0/8.0	5.0/8.0	5.0/8.0	5.0/8.0	5.0/8.0	5.0/8.0	5.0/8.0	5.0/8.0	5.0/8.0	5.0/5.0	5.0/8.0
	4.2	Height of mast, lowered	h1 (mm)	2288	2288	2330	2330	2330	2288	2288	2330	2330	2330	2230	2730	2330
	4.3	Free lift	h2 (mm)	150	150	150	150	150	150	150	150	150	150	150	150	150
	4.4	Lift	h3 (mm)	3230	3230	3295	3295	3295	3230	3230	3295	3295	3295	3095	4095	3295
	4.5	Height of mast, extended	h4 (mm)	3901	3901	4061	4061	4061	3901	3901	4061	4061	4061	3861	4861	4061
	4.7	Height of overhead guard (cabin)	h6 (mm)	2275	2275	2322	2322	2322	2275	2275	2322	2322	2322	2222	2722	2322
	4.8	Height of seat/stand on platform	h7 (mm)	1074	1074	1119	1119	1119	1074	1074	1119	1119	1119	1119	1519	1119
	4.12	Towing coupling height	h10 (mm)	621	621	668	643	643	621	621	668	643	643	643	643	643
4.19	Overall length	l1 (mm)	3659	3699	3738	3756	3796	3659	3699	3738	3756	3796	3796	3796	3796	
4.20	Length to fork face	l2 (mm)	2659	2699	2738	2756	2796	2659	2699	2738	2756	2796	2796	2796	2796	
4.21	Overall width	b1/b2 (mm)	1180/1176	1180/1176	1256/1176	1256/1176	1256/1176	1180/1176	1180/1176	1256/1176	1256/1176	1256/1176	1256/1176	1256/1176	1256/1176	
4.22	Fork dimensions DIN ISO 2331	s/e/l (mm)	45 x 100 x 1000	45 x 100 x 1000	45 x 100 x 1000	45 x 100 x 1000	50 x 120 x 1000	45 x 100 x 1000	45 x 100 x 1000	45 x 100 x 1000	45 x 100 x 1000	45 x 100 x 1000	50 x 120 x 1000	50 x 120 x 1000	50 x 120 x 1000	
4.23	Fork carriage to ISO 2328, class/type A, B		2A	2A	2A	3A	3A	2A	2A	2A	3A	3A	3A	3A	3A	
4.24	Width of fork carriage	b3 (mm)	1150	1150	1150	1150	1150	1150	1150	1150	1150	1150	1150	1150	1150	
4.31	Ground clearance, below mast	m1 (mm)	121	121	124	123	121	121	121	124	123	121	121	120	121	
4.32	Ground clearance, centre of wheelbase	m2 (mm)	130	130	177	176	175	130	130	177	176	175	175	174	175	
4.34.1	Aisle width for pallets 1000 x 1200 crossways	Ast (mm)	3990 ¹⁾	4032 ¹⁾	4071 ¹⁾	4090 ¹⁾	4132 ¹⁾	3990 ¹⁾	4032 ¹⁾	4071 ¹⁾	4090 ¹⁾	4132 ¹⁾	4132 ¹⁾	4132 ¹⁾	4132 ¹⁾	
4.34.2	Aisle width with pallet 800 x 1200 along forks	Ast (mm)	4190 ¹⁾	4232 ¹⁾	4271 ¹⁾	4290 ¹⁾	4332 ¹⁾	4190 ¹⁾	4232 ¹⁾	4271 ¹⁾	4290 ¹⁾	4332 ¹⁾	4332 ¹⁾	4332 ¹⁾	4332 ¹⁾	
4.35	Turning radius	Wa (mm)	2373	2415	2415	2441	2478	2373	2415	2415	2441	2478	2478	2478	2478	
4.36	Minimum pivoting point distance	b13 (mm)	645	659	659	668	680	645	659	659	668	680	680	680	680	
Performance	5.1	Travel speed, with/without load	(km/h)	22/22	22/22	22/22	22/22	22/22	22/22	22/22	22/22	22/22	22/22	22/22	22/22	
	5.2	Lifting speed, with/without load	(m/s)	0.53/0.55	0.53/0.55	0.53/0.56	0.53/0.56	0.53/0.56	0.53/0.55	0.53/0.55	0.53/0.56	0.53/0.56	0.45/0.56	0.53/0.56	0.53/0.55	0.45/0.56
	5.3	Lowering speed, with/without load	(m/s)	0.56/0.56	0.56/0.56	0.56/0.56	0.56/0.56	0.56/0.56	0.56/0.56	0.56/0.56	0.56/0.56	0.56/0.56	0.56/0.56	0.56/0.56	0.56/0.52	0.56/0.56
	5.5	Tractive force, with/without load	(N)	14.553/14.330	14.420/14.575	19.722/16.611	19.593/17.132	19.428/17.973	14.558/14.089	14.425/14.331	19.727/16.364	19.598/16.886	19.433/17.721	19.350/19.900	19.430/17.770	19.420/17.760
	5.7	Climbing ability, with/without load	(%)	28.0/34.0	24.0/31.0	32.0/33.0	27.0/30.0	27.0/30.0	28.0/34.0	24.0/31.0	32.0/33.0	27.0/30.0	27.0/30.0	22.9/28.4	24.1/28.4	23.9/27.8
	5.9	Acceleration time, with/without load	(s)	5.6/5.1	5.8/5.1	5.4/4.6	5.6/4.7	5.8/4.9	5.4/4.7	5.6/4.7	5.8/5.0	5.8/5.0	5.9/5.0	5.8/4.9	5.8/4.9	6.0/5.0
5.10	Service brake		hydrostatic	hydrostatic	hydrostatic	hydrostatic	hydrostatic	hydrostatic	hydrostatic	hydrostatic	hydrostatic	hydrostatic	hydrostatic	hydrostatic	hydrostatic	
Drive	7.1	Engine manufacturer/type		Deutz TCD 2.2 L3	Deutz TCD 2.2 L3	Deutz TCD 2.2 L3	Deutz TCD 2.2 L3	Deutz TCD 2.2 L3	Deutz G 2.2 L3	Deutz G 2.2 L3	Deutz G 2.2 L3	Deutz G 2.2 L3	Deutz G 2.2 L3	Deutz TCD 2.2 L3	Deutz TCD 2.2 L3	Deutz G 2.2 L3
	7.2	Engine performance according to DIN ISO 1585	(kW)	30	30	45	45	45	36.4	36.4	40	40	40	45	45	36.2
	7.3	Rated speed	(1/min)	2300	2300	2100	2100	2100	2300	2300	2600	2600	2600	2100	2100	2600
	7.4	Number of cylinders/displacement	(-/cm³)	3/2194	3/2194	3/2194	3/2194	3/2194	3/2194	3/2194	3/2194	3/2194	3/2194	3.0/2194	3.0/2194	3.0/2194
	7.5 c	Fuel consumption in accordance with EN 16796	(l/h)	2.5	2.7	2.9	3.0	3.1						3.1	3.1	3.2
	7.5 d	Fuel consumption in accordance with EN 16796	(kg/h)						2.3	2.5	2.7	2.8	2.9			4.38 (H); 3.89 (L)
	7.5.1	CO2 equivalent according to EN 16796	(kg/h)	7.9	8.6	9.2	9.5	9.9	7.8	8.5	9.2	9.5	9.8	9.9	9.9	10
Others	8.1	Type of drive unit		hydrostatic/stepless	hydrostatic/stepless	hydrostatic/stepless	hydrostatic/stepless	hydrostatic/stepless	hydrostatic/stepless	hydrostatic/stepless	hydrostatic/stepless	hydrostatic/stepless	hydrostatic/stepless	hydrostatic/stepless	hydrostatic/stepless	
	10.1	Operating pressure for attachments	(bar)	200	230	200	225	245	200	230	200	225	245	245	245	
	10.2	Oil flow for attachments	(l/min)	50	50	50	50	50	50	50	50	50	50	50	50	
	10.7	Sound pressure level LpAZ (at the driver's seat)	(dB(A))	79	79	79	79	79	79	79	79	79	79	79	79	79 ²⁾
10.8	Towing coupling, design/type, DIN 15 170		similar to form H	similar to form H	similar to form H	similar to form H	similar to form H	similar to form H	similar to form H	similar to form H	similar to form H	similar to form H	similar to form H	similar to form H	similar to form H	

1) Including a 200 mm operating aisle clearance
2) With full cabin

MAST TABLES

STANDARD MAST (in mm)

Series	1532							
Lift	h3: 3030	h3: 3230	h3: 3430	h3: 3730	h3: 4030	h3: 4530	h3: 5030	
Height measurements	h1: 2187 h4: 3702	h1: 2287 h4: 3902	h1: 2387 h4: 4102	h1: 2537 h4: 4402	h1: 2687 h4: 4702	h1: 2937 h4: 5202	h1: 3187 h4: 5702	h2: 150
Model								
H20/600	○	○	○	○	○	○	○	
H25	○	○	○	○	○	○	○	

Series	1533							
Lift	h3: 3095	h3: 3295	h3: 3395	h3: 3695	h3: 3995	h3: 4495	h3: 4995	
Height measurements	h1: 2224 h4: 3856	h1: 2324 h4: 4056	h1: 2374 h4: 4156	h1: 2524 h4: 4456	h1: 2674 h4: 4756	h1: 2924 h4: 5256	h1: 3174 h4: 5756	h2: 150
Model								
H25/600	○	○	○	○	○	○	○	
H30	○	○	○	○	○	○	○	
H35	○	○	○	○	○	○	○	

DUPLEX MAST (in mm)

Series	1532					1533				
Lift	h3: 3100	h3: 3300	h3: 3400	h3: 3800	h3: 4100	h3: 3165	h3: 3365	h3: 3765	h3: 4065	
Height measurements	h1: 2134 h2: 1444 h4: 3791	h1: 2234 h2: 1544 h4: 3991	h1: 2284 h2: 1594 h4: 4091	h1: 2484 h2: 1794 h4: 4491	h1: 2634 h2: 1944 h4: 4791	h1: 2179 h2: 1394 h4: 3951	h1: 2279 h2: 1494 h4: 4151	h1: 2479 h2: 1694 h4: 4551	h1: 2629 h2: 1844 h4: 4851	
Model										
H20/600	○	○	○	○	○	–	–	–	–	
H25	○	○	○	○	○	–	–	–	–	
H25/600	–	–	–	–	–	○	○	○	○	
H30	–	–	–	–	–	○	○	○	○	
H35	–	–	–	–	–	○	○	○	○	

TRIPLEX MAST (in mm)

Series	1532					
Lift	h3: 4610	h3: 4910	h3: 5060	h3: 5560	h3: 6010	h3: 6510
Height measurements	h1: 2134 h2: 1444 h4: 5299	h1: 2234 h2: 1544 h4: 5599	h1: 2284 h2: 1594 h4: 5749	h1: 2484 h2: 1794 h4: 6249	h1: 2634 h2: 1944 h4: 6699	h1: 2834 h2: 2144 h4: 7199
Model						
H20/600	○	○	○	○	○	○
H25	○	○	○	○	○	○

Series	1533					
Lift	h3: 4680	h3: 4980	h3: 5330	h3: 5930	h3: 6430	h3: 6880
Height measurements	h1: 2179 h4: 5464	h1: 2279 h2: 1494 h4: 5764	h1: 2429 h2: 1644 h4: 6114	h1: 2629 h2: 1844 h4: 6714	h1: 2829 h2: 2044 h4: 7214	h1: 2979 h2: 2194 h4: 7664
Model						
H25/600	○	○	○	○	○	○
H30	○	○	○	○	○	○
H35	○	○	○	○	○	○

○ Optional equipment

– Not available

h1: Height of mast, lowered

h2: Free lift

h3: Lift

h4: Height of mast, extended

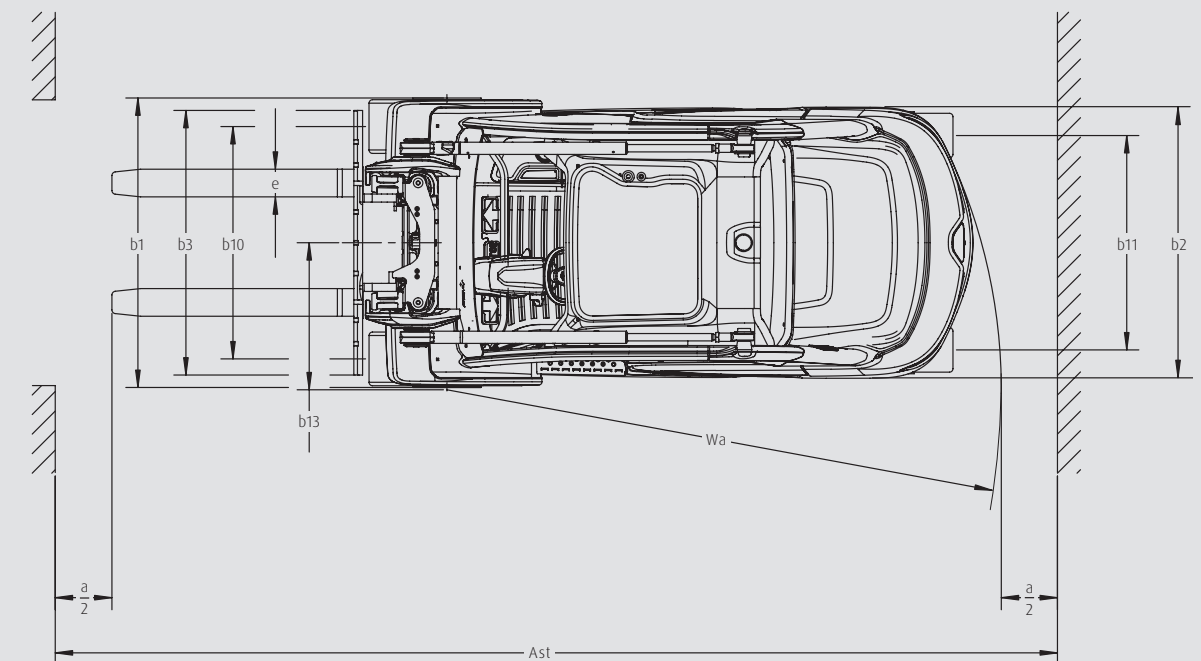
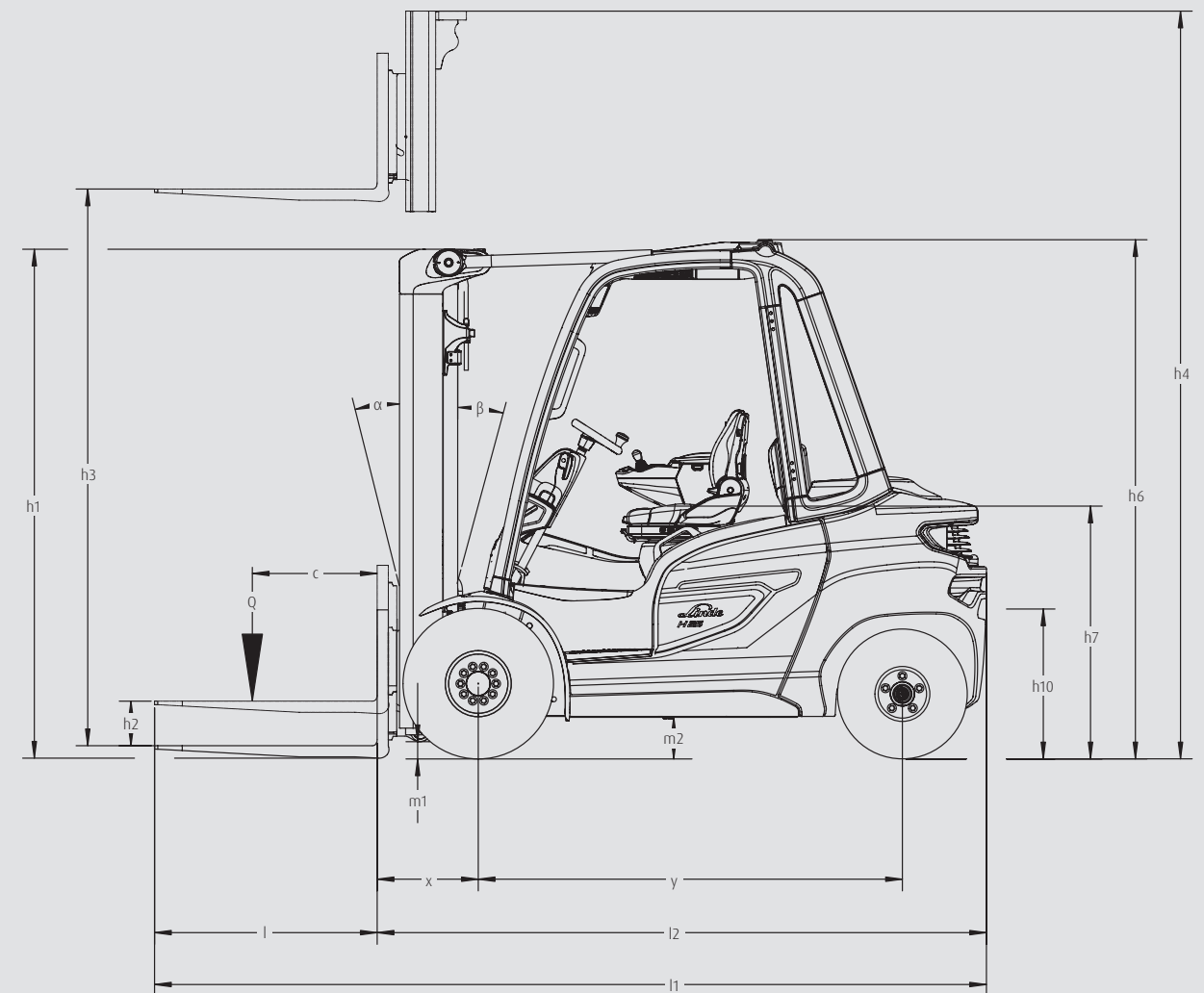

Safety distance a = 200 mm

CHARACTERISTICS



Driver workplace

Ergonomics

- Ergonomic and intuitive operating concept maximizes operator comfort
- Components decoupled from the chassis (axles, mast and tilt cylinder) protect against impacts and vibrations
- Large selection of ergonomic seats protects against postural injuries
- 3.5-inch display provides permanent overview of all important information



Linde Load Control

Handling

- Linde Load Control and Dual pedal control guarantee precise control of all driving and mast movements
- Freely programmable buttons in the armrest ensure quick access to frequently used functions
- Overhead tilt cylinders guarantee torsional stability and high residual load capacities at large lifting heights
- Minimized fuel consumption reduces operating costs



All-round visibility

Safety

- Optimized design provides outstanding visibility in all directions
- Roof with narrow cross struts or armored glass makes working easier at large lifting heights
- The truck's low center of gravity and a high-mounted steering axle improves stability while cornering
- Linde Curve Assist and Linde Load Assist reduce the risk of tipping and loading accidents



Easy service access

Service

- Robust construction with low-wear and maintenance-free components ensure high truck availability
- Truck Health Monitoring protects the engine in extreme outdoor temperatures
- Linde Engine Protection System (LEPS) provides additional protection against engine damage
- Extra-large service openings make maintenance easy

Subject to modification in the interest of progress. Illustrations and technical details could include options and not binding for actual constructions. All dimensions subject to usual tolerances.

Linde Material Handling

Linde

ncnielsen

Nørregade 66, DK-7860 Balling | Tlf.: +45 99 83 83 83
nc-nielsen.dk | info@nc-nielsen.dk